

## 2021 Ram 4500/5500

### Jacking Instructions



#### WARNING:

Carefully follow these tire changing warnings to help prevent personal injury or damage to your vehicle:

- Always park on a firm, level surface as far from the edge of the roadway as possible before raising the vehicle.
- Turn on the Hazard Warning Flashers.
- Apply the parking brake firmly and set the transmission in PARK.
- Block the wheel diagonally opposite the wheel to be raised.
- Never start or run the engine with the vehicle on a jack.
- Do not let anyone sit in the vehicle when it is on a jack.
- Do not get under the vehicle when it is on a jack. If you need to get under a raised vehicle, take it to a service center where it can be raised on a lift.
- Only use the jack in the positions indicated and for lifting this vehicle during a tire change.
- If working on or near a roadway, be extremely careful of motor traffic.
- To assure that spare tires, flat or inflated, are securely stowed, spares must be stowed with the valve stem facing the ground.

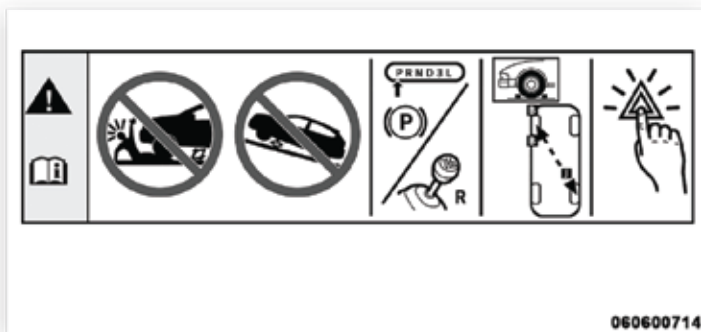

Jack Warning Label

#### CAUTION:

Do not attempt to raise the vehicle by jacking on locations other than those indicated in the Jacking Instructions for this vehicle.

- 1 If equipped, remove the spare wheel, jack, and tools from storage.
- 2 Using the lug wrench, loosen, but do not remove, the lug nuts by turning them counterclockwise one turn while the wheel is still on the ground.
- 3 When changing the front wheel, assemble the jack driver to the jack and connect the jack driver to the extension tube. Place the jack under the axle as close to the tire as possible with the jack driver extending to the front. Connect the extension tubes and lug wrench.

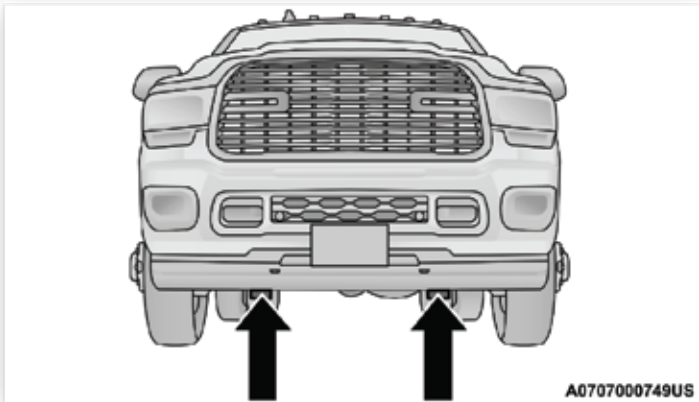

Front Jacking Locations

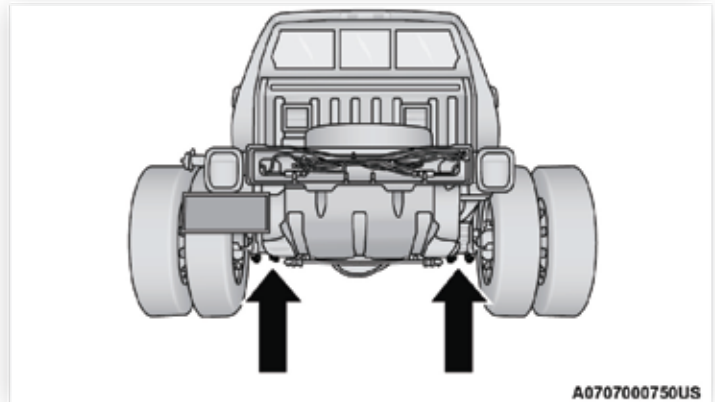

Rear Jacking Location

When changing a rear wheel, assemble the jack driver to the jack and connect the jack driver to the extension tubes. Securely place the jack under the sway bar bracket (unless both tires are flat on one side, then place jack under shock bracket) facing forward in vehicle. Connect the extension tubes and lug wrench.

Before raising the wheel off the ground, make sure that the jack will not damage surrounding truck parts and adjust the jack position as required.

**Note:** If the jack will not lower by turning the dial (thumbwheel) by hand, it may be necessary to use the jack driver in order to lower the jack.

- 4 By rotating the lug wrench clockwise, raise the vehicle until the wheel just clears the surface.

**WARNING:**

Raising the vehicle higher than necessary can make the vehicle less stable. It could slip off the jack and hurt someone near it. Raise the vehicle only enough to remove the tire.

- 5 Remove the lug nuts and pull the wheel off. Install the spare wheel and lug nuts with the cone shaped end of the nuts toward the wheel on Single Rear-Wheel (SRW) models. On Dual Rear-Wheel models (DRW) the lug nuts are a two-piece assembly with a flat face. Lightly tighten the nuts. To avoid risk of forcing the vehicle off the jack, do not fully tighten the nuts until the vehicle has been lowered.
- 6 Using the lug wrench, finish tightening the nuts using a crisscross pattern. If in doubt about the correct tightness, have them checked with a torque wrench by an authorized dealer or at a service station.

**WARNING:**

A loose tire or jack thrown forward in a collision or hard stop, could endanger the occupants of the vehicle. Always stow the jack parts and the spare tire in the places provided.

- 7 Install wheel center cap (if equipped) and remove wheel blocks. Do not install chrome or aluminum wheel center caps on the spare wheel. This may result in cap damage.
- 8 Lower the jack to its fully closed position. If the jack will not lower by turning the dial (thumbwheel) by hand, it may be necessary to use the jack driver in order to lower the jack. Stow the replaced tire, jack, and tools as previously described.
- 9 Adjust the tire pressure when possible.
- 10 After 25 miles (40 km), check the lug nut torque with a torque wrench to ensure that all lug nuts are properly seated against the wheel.