



2023 Nissan Ariya

Electric Parking Brake Release Procedure



Releasing Electric Parking Brake Using Parking Brake Switch

If equipped, the electric parking brake can be released by operating the parking brake switch shown below.

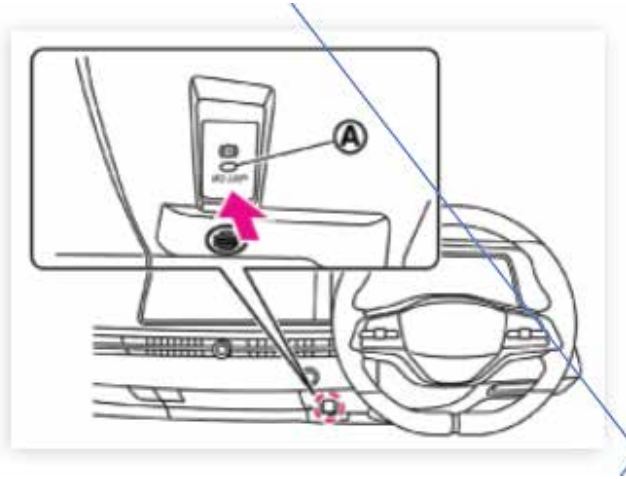

1. With the power switch in the ON position, depress the brake pedal and push the switch down. The indicator light (A) will turn off.
2. Check that the electric parking brake indicator light (or PARK) goes out.

Releasing Electric Parking Brake Where Parking Brake Switch Cannot Be Used

If the vehicle is equipped with an electric parking brake and cannot be released using the parking brake switch, the following steps can be used to mechanically release the electric parking brake on each rear brake caliper assembly.

- + **To avoid possible personal injury or vehicle damage, use wheel chocks or take appropriate steps to prevent the vehicle from rolling freely.**
- + **Never reuse the parking brake actuator. Doing so may cause brake system failure and possibly result in serious personal injury.**

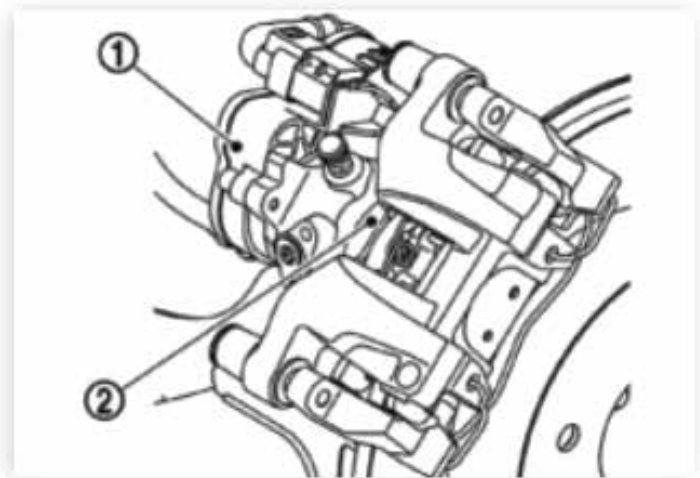
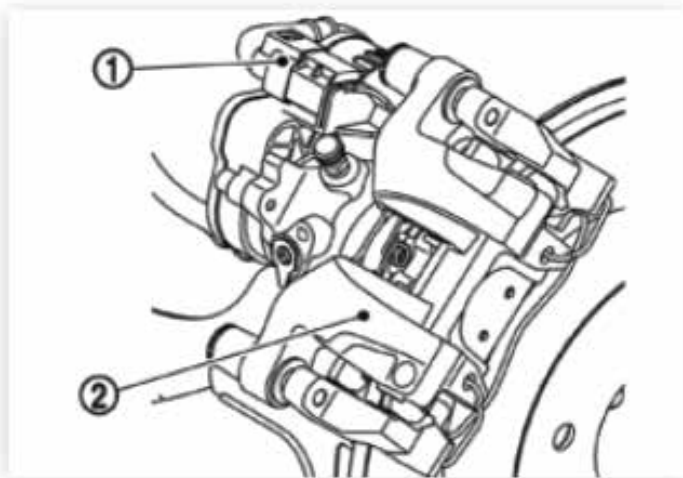

1. Disconnect the parking brake actuator harness connector (1) from the rear caliper assembly (2).
2. Remove the parking brake actuator (1) from the rear brake caliper assembly (2).

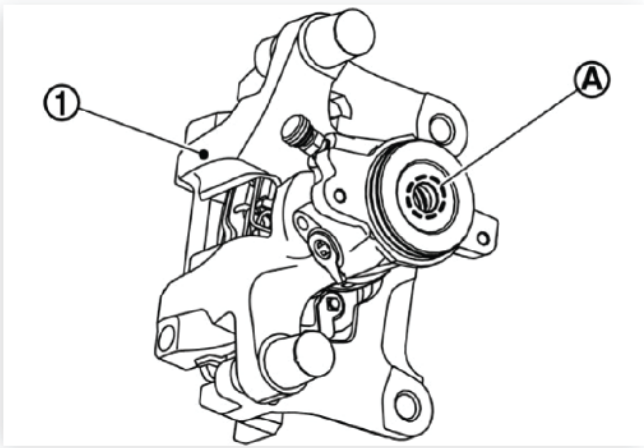

- 3 Rotate the rear brake caliper assembly (1) spindle part (A) clockwise to release the parking brake.

P (Park) Position Release Procedure:

If you need to release the vehicle from the P (Park) position, proceed as follows. When the power switch is turned OFF, ARIYA automatically shifts to P position.

To avoid possible personal injury or vehicle damage, use wheel chocks or take appropriate steps to prevent the vehicle from rolling freely. Never set the vehicle in READY state.

Be sure to firmly position wheel chocks before P (Park) position is released.

1. Twelve volt electric power is supplied with booster cable to the 12-volt battery.
2. Turn the power switch ON by pushing the power switch 2 times without pressing the brake pedal.
3. Check that the parking brake is activated. (Check that the indicator lamp for the parking brake is ON.)
4. Place the selector lever in the N (Neutral) position.
 - a. Close all doors, depress the brake pedal and shift to “N” position.
After maintaining this status for some time, check that the shift position indicator is indicated to “N” position.
5. Open hood and remove fuse and fusible link block cover (1).

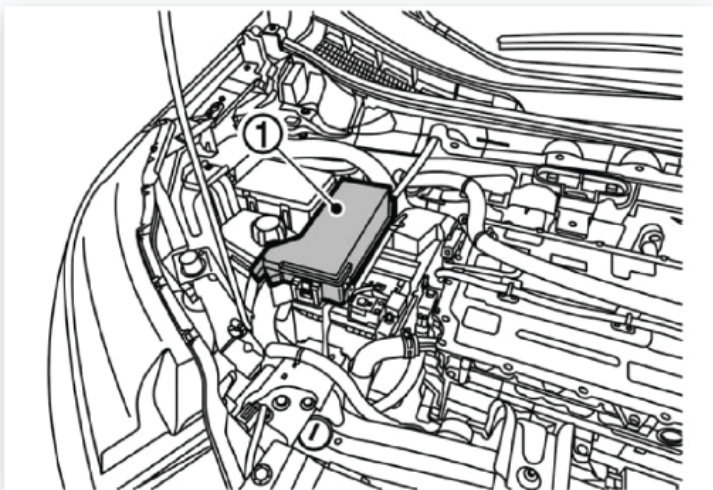

NOTE: When the door is open in the “N” position, the warning chime is sounded.

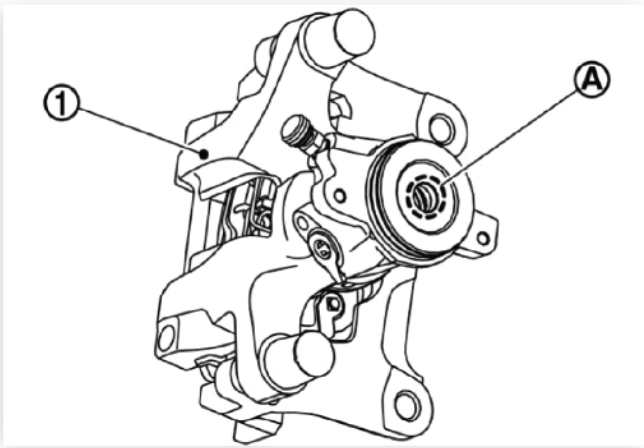

6. Remove 30A fuse (shown as SHIFT MOTOR) (1).

NOTE: Vehicle Front

7. Release parking brake.
8. Set the power switch to OFF.
9. Release the parking brake before moving the vehicle.
10. Move the vehicle while the power switch is OFF.

To avoid possible personal injury or vehicle damage, use wheel chocks or take appropriate steps to prevent the vehicle from rolling freely. Never set the vehicle in READY state.

Be sure to firmly position wheel chocks when P (Park) position is manually released.

Reset Procedure:

1. Disconnect the 12V battery cable from the negative terminal.
2. Install 30A fuse (shown as SHIFT MOTOR).
3. Install fuse and fusible link block cover.
4. Connect the 12V battery cable to the negative terminal.
5. Wait for 5 seconds after set the power switch to ON and then push P position switch.
6. Set the power switch to OFF and wait for 5 seconds.