



# 2023 Jeep Grand Cherokee 4XE

## Jacking and Tire Change

Jacking And Tire Changing <sup>1</sup> Use this QR code to access your digital experience.

### WARNING:

- Do not attempt to change a tire on the side of the vehicle close to moving traffic. Pull far enough off the road to avoid the danger of being hit when operating the jack or changing the wheel.
- Being under a jacked-up vehicle is dangerous. The vehicle could slip off the jack and fall on you. You could be crushed. Never put any part of your body under a vehicle that is on a jack. If you need to get under a raised vehicle, take it to a service center where it can be raised on a lift.
- Never start or run the engine while the vehicle is on a jack.
- The jack is designed to be used as a tool for changing tires only. The jack should not be used to lift the vehicle for service purposes. The vehicle should be jacked on a firm level surface only. Avoid ice or slippery areas.

### Note:

If your vehicle is equipped with an air suspension system, there is a feature which allows the automatic leveling to be disabled before changing a tire. This feature can be activated through the Uconnect system.

### Note:

Before changing a tire or using the jack please disable the hands free lift gate, This feature can be disabled through the Uconnect system.

## Preparations For Jacking

1. Park the vehicle on a firm, level surface as far from the edge of the roadway as possible. Avoid icy or slippery areas.

### WARNING:

Do not attempt to change a tire on the side of the vehicle close to moving traffic. Pull far enough off the road to avoid being hit when operating the jack or changing the wheel.

2. Turn on the Hazard Warning Flashers.
3. Apply the parking brake.
4. Place the gear selector into PARK (P).
5. Turn OFF the ignition.
6. Block both front and rear of the wheel diagonally opposite of the jacking position. For example, if changing the left front wheel, block the right rear wheel.

# Jacking Instructions

## WARNING:

Carefully follow these tire changing warnings to help prevent personal injury or damage to your vehicle:

- Always park on a firm, level surface as far from the edge of the roadway as possible before raising the vehicle.
- Turn on the Hazard Warning Flashers.
- Apply the parking brake firmly and set the transmission in PARK.
- Block the wheel diagonally opposite the wheel to be raised.
- Never start or run the engine with the vehicle on a jack.
- Do not let anyone sit in the vehicle when it is on a jack.
- Do not get under the vehicle when it is on a jack. If you need to get under a raised vehicle, take it to a service center where it can be raised on a lift.
- Only use the jack in the positions indicated and for lifting this vehicle during a tire change.
- If working on or near a roadway, be extremely careful of motor traffic.
- To assure that spare tires, flat or inflated, are securely stowed, spares must be stowed with the valve stem facing the ground.



Jack Warning Label

## CAUTION:

Do not attempt to raise the vehicle by jacking on locations other than those indicated in the Jacking Instructions for this vehicle.

1. Loosen (but do not remove) the wheel lug nuts, using the lug wrench by turning them counterclockwise, one turn, while the wheel is still on the ground.



Loosen Lug Nuts

A0707001148US

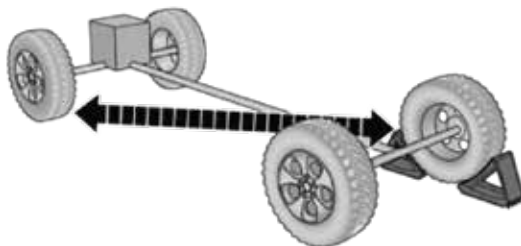

A0707001133US

Wheel Blocked Example

2. Assemble the jack and jacking tools.

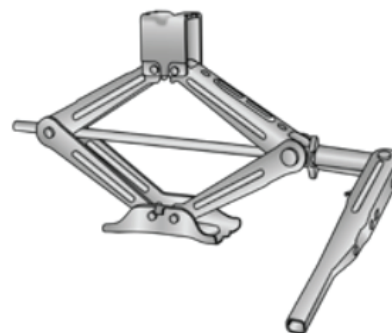

Jack And Tools Assembled

A0707001145US

## Note:

Passengers should not remain in the vehicle when the vehicle is being raised or lifted.

## Note

Proper placement for the front and rear jacking locations is critical. See the following images for proper jacking locations.

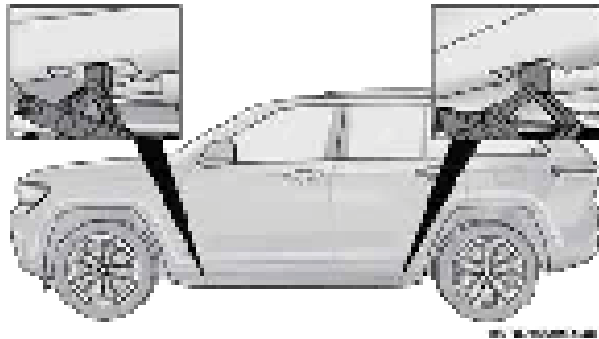

## Jacking Locations

2. For the front axle, place the jack on the body flange just behind the front tire as indicated by the triangular lift point symbol on the sill molding. Do not raise the vehicle until you are sure the jack is fully engaged.

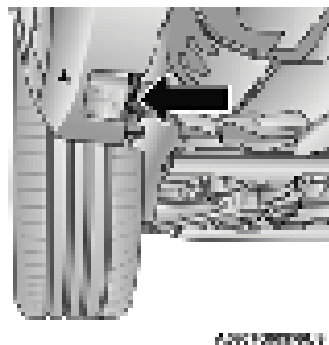

## Front Lifting Point

## Note

The jack must be placed straight on with handles facing outwards.

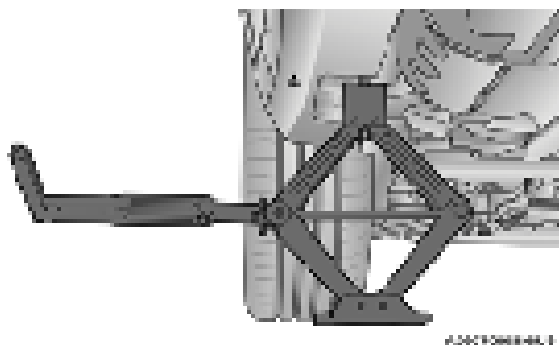

## Front Jacking Location

4. For a rear tire, place the pick in the slot on the rear tie-down bracket, just forward of the rear tire (as indicated by the triangular lift point symbol on the sill molding). Do not raise the vehicle until you are sure the pick is fully engaged.

**CAUTION**

Do NOT raise the vehicle by the body side sill molding. Be sure the pick is placed in the proper engagement location on the inside of the panel. Damage to the vehicle may occur if the procedure is not properly followed.

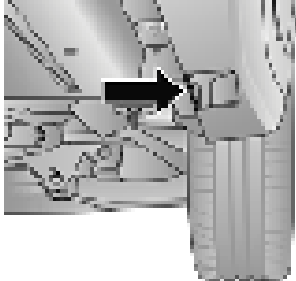

AS001088001.0

**Rear Lifting Point**

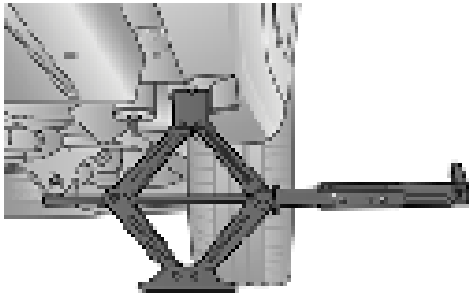

AS001088001.0

**Rear Jacking Location**

5. Raise the vehicle by turning the pick so it's clockwise. Raise the vehicle only until the tire just clears the surface and enough clearance is obtained to install the spare tire. Minimum lift (1") provides maximum stability.

**WARNING**

Raising the vehicle higher than necessary can make the vehicle less stable. It could slip off the jack and hurt someone near it. Raise the vehicle only enough to remove the tire.

6. Remove the lug nuts and wheel.

7. Position the spare wheel(s) on the vehicle and install the lug nuts with the cone-shaped end toward the wheel. Lightly tighten the nuts.

**CAUTION**

Be sure to mount the spare tire with the valve stem facing outward. The vehicle could be damaged if the inflatable spare tire is mounted incorrectly.

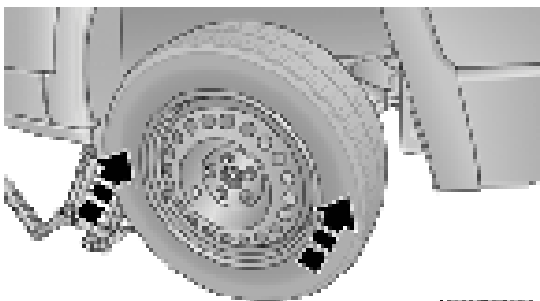

AS001088001.0

**Mounting Spare Tire**

## WARNING

To avoid the risk of losing the vehicle off the jack, do not tighten the wheel nuts fully until the vehicle has been lowered. Failure to follow this warning may result in serious injury.

8. Lower the vehicle by turning the jack screw counterclockwise, and remove the jack and wheel blocks.
9. Finish tightening the lug nuts. Push down on the wrench while at the end of the handle for increased leverage. Tighten the lug nuts in a star pattern until each nut has been tightened twice. For correct lug nut torque. If in doubt about the correct tightness, have them checked with a torque wrench by an authorized dealer or at a service station.

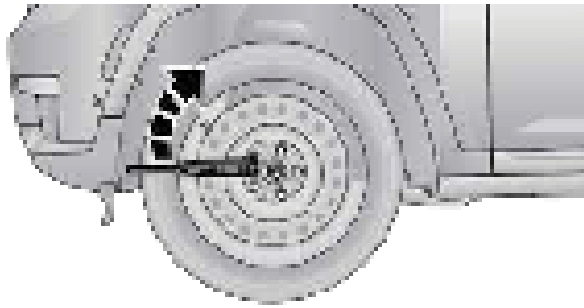

AD200021047

### Tighten Lug Nuts

10. Lower the jack to the fully closed position.
11. Return the Jack and tools back into the jack storage bin. Reinstall the jack storage cover by firmly pushing down until the two side clips lock into position.
12. After 25 miles (40 km), check the lug nut torque with a torque wrench to ensure that all lug nuts are properly sealed against the wheel.
13. Have the aluminum road wheel and tire repaired as soon as possible and properly secure the spare tire, jack and tool kit.

## Note

Do not drive with the spare tire installed for more than 50 miles (80 km) at a max speed of 50 mph (80 km/h).

## WARNING

A loose tire or jack thrown forward in a collision or hard stop could endanger the occupants of the vehicle. Always store the jack parts and the spare tire in the places provided. Have the deflated (Tb) tire repaired or replaced immediately.

### Second Row Seating — T Equipped

1. Securely store the road wheel in the cargo area.



AD200021051

### Road Wheel Installed in Spare Tire Location

2. Turn the handle clockwise until secured.



Rear Floor Nut Fastener

#### Third Row Seating — 1 Equipped

1. Position the wheel behind the rear floor bumper being outward. Push the end of the winch's cable, spring and steel sleeve through the back of the road wheel. Making sure the valve stem is facing the ground when the wheel is moved.

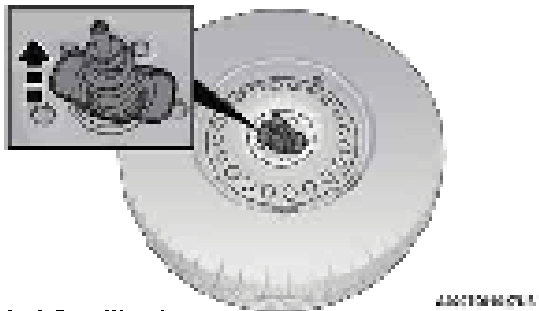

Installing Winch

2. Slide the road wheel on the ground until it is directly under the winch and between the rear floor bumper and exhaust system heat shields. Place the tire by turning the lug wrench on the winch extension clockwise until it dislatches three times to make sure the cable is tight.

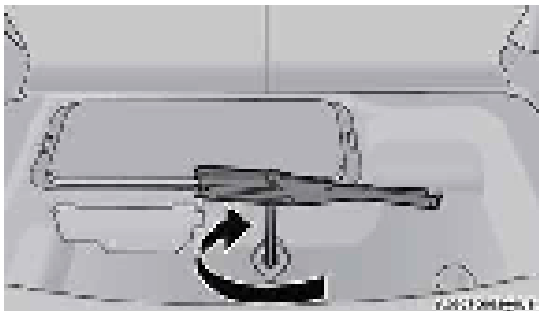

Winch Winch Rotation

#### CAUTION

The winch mechanism is designed for use with the jack winch extension tool only. Use of air wrench or power tool may damage the winch.



Road Wheel Installed in Spare Location

# Jack Location

The scissor-type jack and tire changing tools are located in the rear cargo area, under the load floor.

## Note

Depending on the vehicle's trim level, the jacking tool locations vary from second and third row seating.

1. Locate and lift up on the load floor handle.

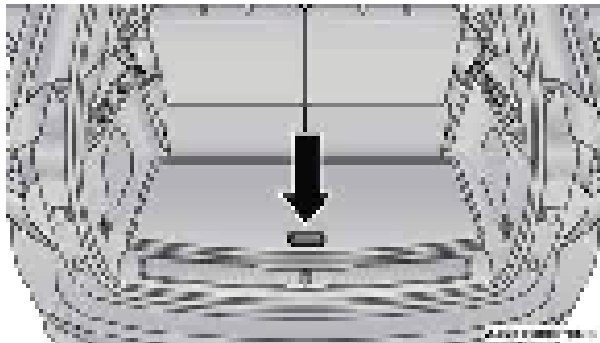

Load Floor Handle

2. Access the jack and tool storage.



Jack Storage Location (Second Row Seating)

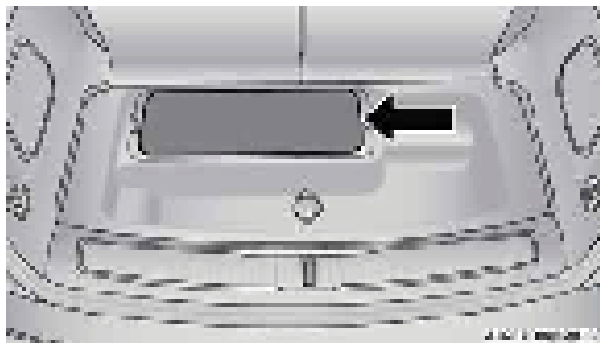

Jack Storage Location (Third Row Seating With Air Suspension)

3. Remove the jack storage cover. To remove, firmly press the (F) side tabs inward while lifting up or out.

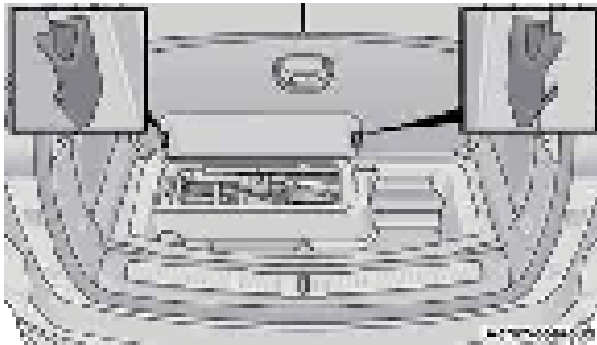

Jack Storage Cover Tabs

4. Release the Velcro straps and pull outward or up on the pack and tools to remove.

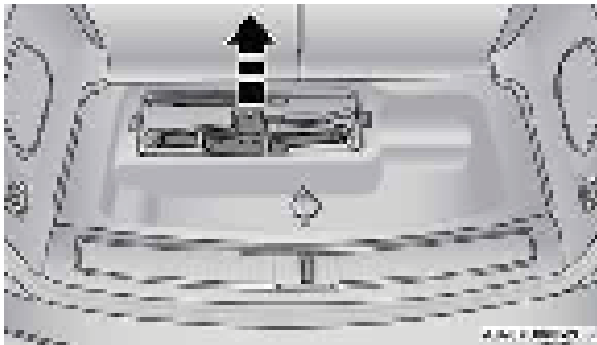

Jack Removal (Third Row Seating With Air Suspension)

5. Jack And Tools Description

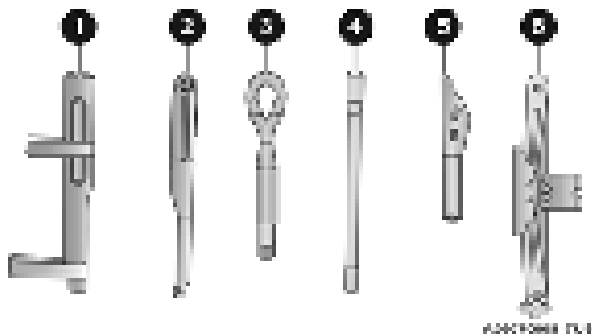

Jack And Tools

1 — Jack Tool Bag
2 — Lug Nut Wrench
3 — Tow Hook (if Equipped)
4 — Jack Handle Extension (if Equipped)
5 — Fuel Funnel
6 — Scissor Jack