



## 2023 ProMaster

Jacking and Tire Change

Jacking And Tire Changing <sup>1</sup> Use this QR code to access your digital experience.

### WARNING:

- Do not attempt to change a tire on the side of the vehicle close to moving traffic. Pull far enough off the road to avoid the danger of being hit when operating the jack or changing the wheel.
- Being under a jacked-up vehicle is dangerous. The vehicle could slip off the jack and fall on you. You could be crushed. Never put any part of your body under a vehicle that is on a jack. If you need to get under a raised vehicle, take it to a service center where it can be raised on a lift.
- Never start or run the engine while the vehicle is on a jack.
- The jack is designed to be used as a tool for changing tires only. The jack should not be used to lift the vehicle for service purposes. The vehicle should be jacked on a firm level surface only. Avoid ice or slippery areas.

## Wheel Covers

The wheel covers on the vehicle are held in place by the wheel lug bolts and can be removed after the wheel lug bolts are taken off.

### CAUTION:

Use a back-and-forth motion to remove the hub cap. Do not use a twisting motion when removing the hub cap, damage to the hub cap finish may occur.

## Torque Specifications

Lug Nut/Bolt Torque	**Lug Nut/Bolt Size	Lug Nut/Bolt Socket Size
145 ft-lb (197 N·m)	M16 x 1.50	21 mm

\*\*Use only authorized dealer recommended lug nuts/bolts and clean or remove any dirt or oil before tightening.

Inspect the wheel mounting surface prior to mounting the tire and remove any corrosion or loose particles.

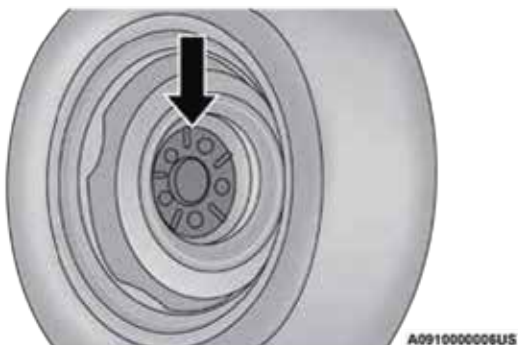

Wheel Mounting Surface

Tighten the lug nuts/bolts in a star pattern until each nut/bolt has been tightened twice. Ensure that the socket is fully engaged on the lug nut/bolt (do not insert it halfway).

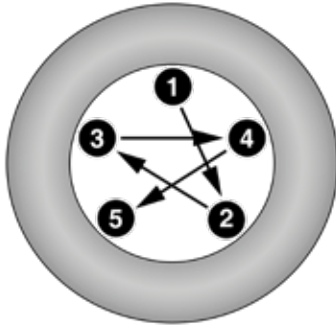

A091000004US

### Torque Patterns

After 25 miles (40 km), check the lug nut/bolt torque to be sure that all the lug nuts/bolts are properly seated against the wheel.

### **WARNING:**

To avoid the risk of forcing the vehicle off the jack, do not tighten the lug nuts/bolts fully until the vehicle has been lowered. Failure to follow this warning may result in personal injury.

## Spare Tire Removal

1. Remove the spare tire before attempting to jack up the vehicle. Attach the lug bolt adapter to the winch extension and insert it into the winch mechanism.

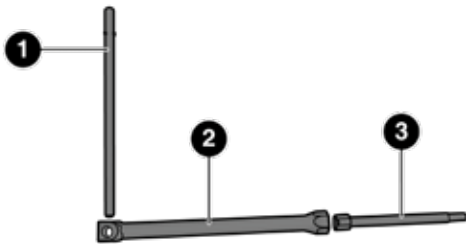

A0707000544US

### Jack Tools

- |                      |
|----------------------|
| 1 — Wrench Handle    |
| 2 — Lug Bolt Adapter |
| 3 — Winch Extension  |

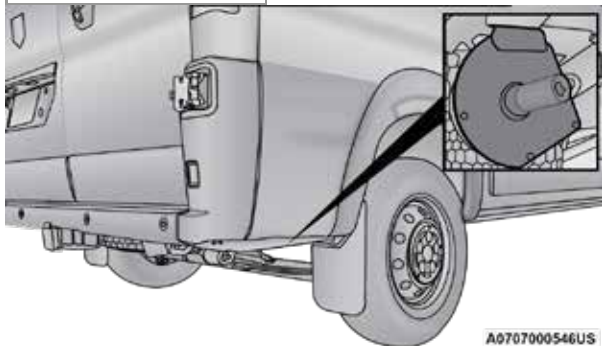

A0707000546US

### Winch Location

The winch mechanism is located under the rear of the vehicle in between the right rear tire and spare tire.

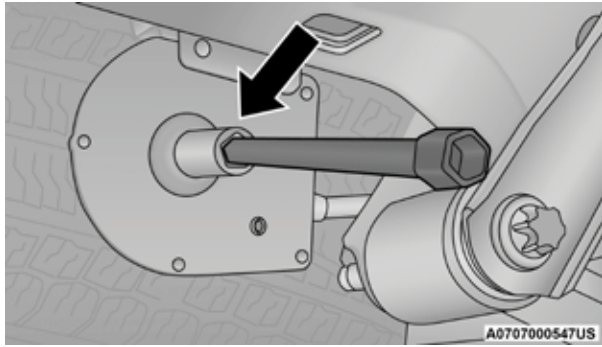

#### Winch Extension

2. Rotate the wheel wrench handle counterclockwise until the spare tire is on the ground with enough cable slack to allow you to pull it out from under the vehicle.

#### CAUTION:

**The winch mechanism is designed for use with the jack wrench extension tool only. Use of air wrench or power tool may damage the winch.**

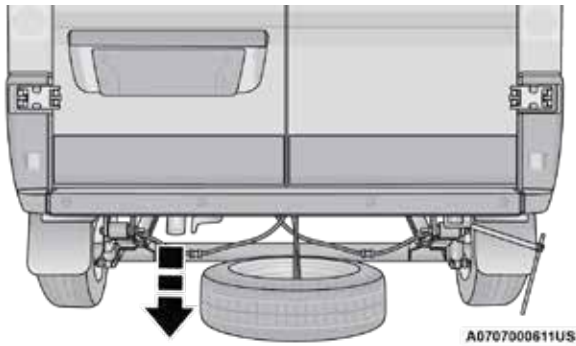

#### Lowering Spare Tire

3. Pull the spare tire out from under the vehicle to gain access to the spare tire retainer.

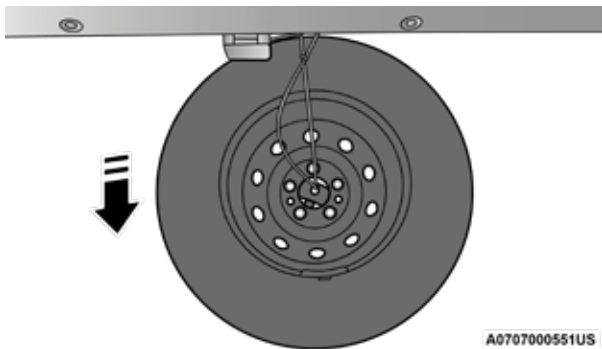

#### Spare Tire

4. Lift the spare tire with one hand to give clearance to tilt the retainer at the end of the cable.

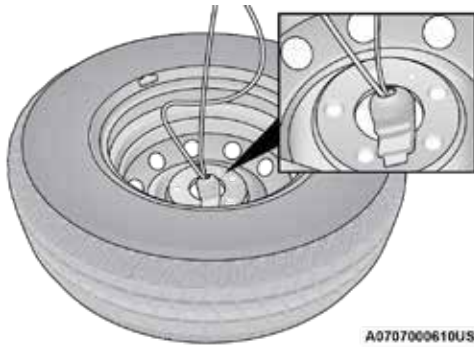

Lifting Spare Tire

5. Pull the retainer through the center of the wheel.

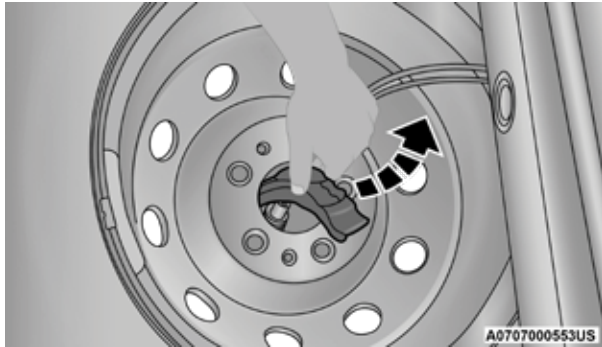

Retainer

## Preparations For Jacking

1. Park the vehicle on a firm, level surface. Avoid ice or slippery areas.

### **WARNING:**

Do not attempt to change a tire on the side of the vehicle close to moving traffic. Pull far enough off the road to avoid being hit when operating the jack or changing the wheel.

2. Turn on the Hazard Warning Flashers.

3. Apply the parking brake firmly.

4. Place the transmission in PARK (P) or REVERSE (R) for manual transmission.

5. Turn the ignition OFF.

6. Block both front and rear of the wheel diagonally opposite of the jacking position. For example, if the driver's front wheel is being changed, block the passenger's rear wheel.

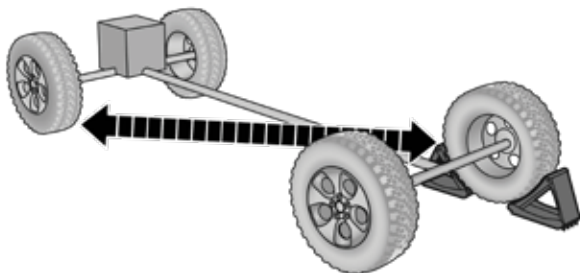

Wheel Blocked Example

### **Note:**

Passengers should not remain in the vehicle when the vehicle is being lifted or raised.

# Jacking Instructions

## WARNING:

Carefully follow these tire changing warnings to help prevent personal injury or damage to your vehicle:

- Always park on a firm, level surface as far from the edge of the roadway as possible before raising the vehicle.
- Turn on the Hazard Warning Flashers.
- Apply the parking brake firmly and place an automatic transmission in PARK; a manual transmission in REVERSE.
- Block the wheel diagonally opposite of the wheel that is to be raised.
- Never start or run the engine with the vehicle on a jack.
- Do not let anyone sit in the vehicle when it is on a jack.
- Do not get under the vehicle when it is on a jack. If you need to get under a raised vehicle, take it to a service center where it can be raised on a lift.
- Only use the jack in the positions indicated and for lifting this vehicle during a tire change.
- If working on or near a roadway, be extremely careful of motor traffic.
- To assure that spare tires, flat or inflated, are securely stowed, spares must be stowed with the valve stem facing the ground.



Jack Warning Label

0606052844



Assembled Jack

A0707000555US

1. Loosen (but do not remove) the wheel lug bolts by turning them counterclockwise one turn while the wheel is still on the ground.
2. There are two jack engagement locations on each side of the vehicle body.

## CAUTION:

**Do not attempt to raise the vehicle by jacking on locations other than those indicated in the Jacking Instructions for this vehicle.**

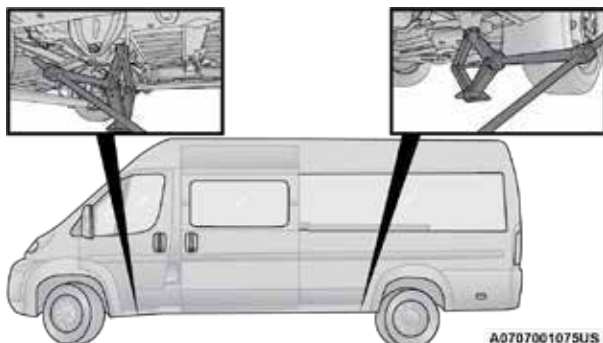

Jacking Engagement Locations

A0707001075US

**Note:**

The front jacking location is located behind the front tire and in front of the driver/passenger door.

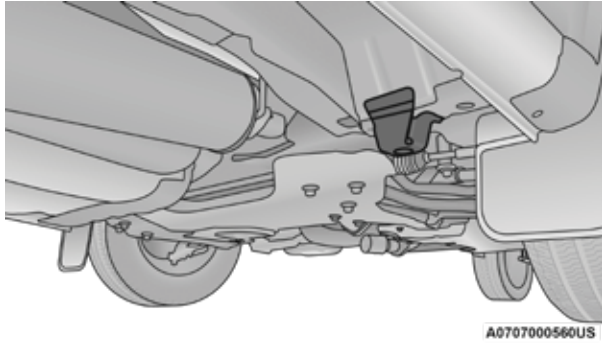

Front Lifting Point

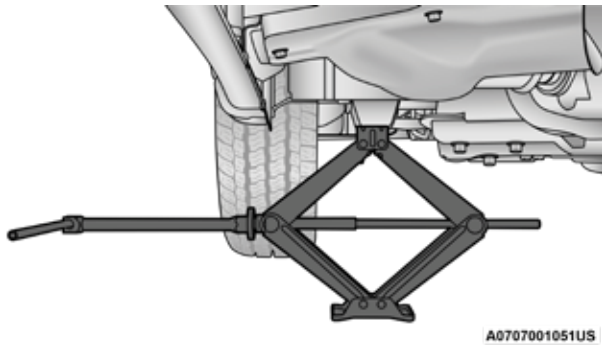

Front Jacking Location

**Note:**

The rear jacking location is located in front of the rear tire and in front of the leaf spring mount.

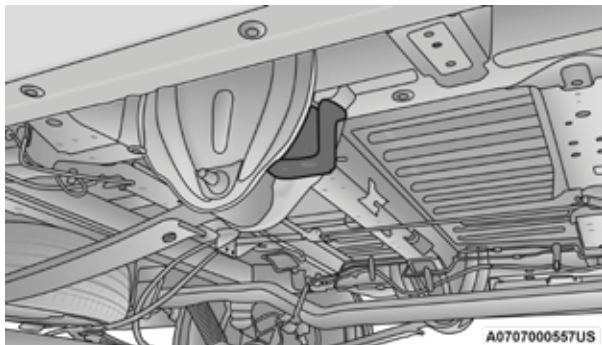

Rear Lifting Point

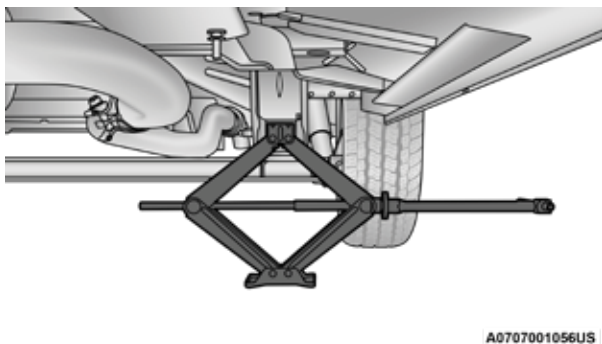

Rear Jacking Location

**WARNING:**

Being under a jacked-up vehicle is dangerous. The vehicle could slip off the jack and fall on you. You could be crushed. Never get any part of your body under a vehicle that is on a jack. If you need to get under a raised vehicle, take it to a service center where it can be raised on a lift.

3. Place the wrench handle and lug bolt adapter on the jack screw and turn clockwise until the jack head is properly engaged in the described location. **Do not raise the vehicle until you are sure the jack is securely engaged.**
4. Raise the vehicle by turning the jack screw clockwise, using the wrench handle and lug bolt adapter. Raise the vehicle only until the tire just clears the surface and enough clearance is obtained to install the spare tire. Minimum tire lift provides maximum stability.

**WARNING:**

Raising the vehicle higher than necessary can make the vehicle less stable. It could slip off the jack and hurt someone near it. Raise the vehicle only enough to remove the tire.

5. Remove the wheel lug bolts. For vehicles with wheel covers, remove the cover from the wheel by hand. Do not pry the wheel cover off. Then pull the wheel off the hub.
6. Install the spare tire. Lightly tighten the wheel lug bolts.

**WARNING:**

To avoid the risk of forcing the vehicle off the jack, do not tighten the wheel nuts fully until the vehicle has been lowered. Failure to follow this warning may result in serious injury.

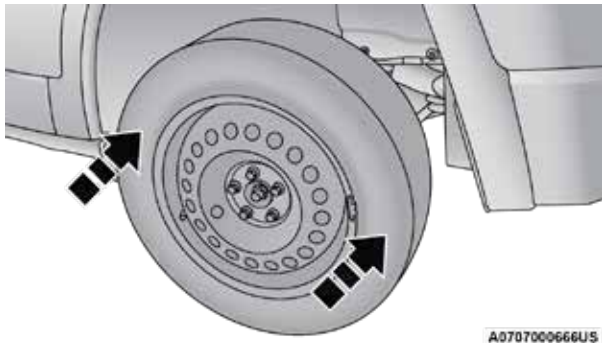

Mounting Spare Tire

**CAUTION:**

**Be sure to mount the spare tire with the valve stem facing outward. The vehicle could be damaged if the spare tire is mounted incorrectly.**

**Note:**

Do not install the wheel cover on the spare tire.

7. Lower the vehicle by turning the jack screw left, making sure it is securely on the ground. Tighten the lug nuts/bolts in a star pattern until each nut/bolt has been tightened twice. Ensure that the socket is fully engaged on the lug nut/bolt (do not insert it halfway).

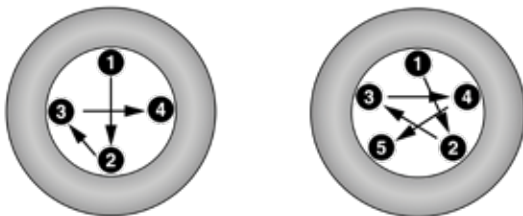

Torque Patterns

8. Lower the jack to its fully-closed position.

9. Stow the damaged wheel/spare tire by reinstalling the wheel retainer and using the cable winch mechanism to securely tighten under the vehicle before driving.

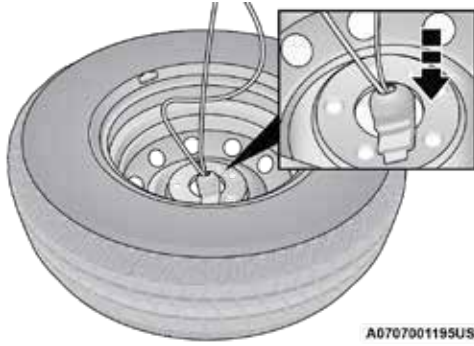

Reinstalling The Retainer

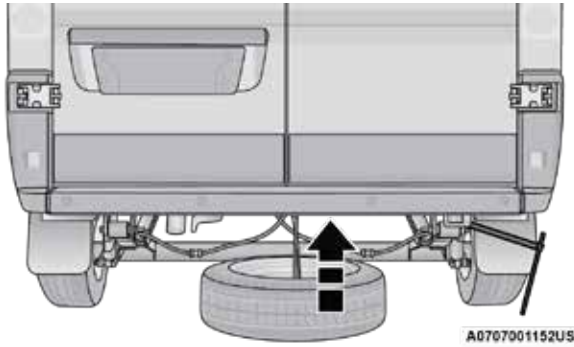

Damaged Wheel Stowage

10. Install the winch extension and **rotate the wrench handle clockwise until the winch mechanism operator hears “three clicks” from the device to indicate the wheel is properly stowed under the vehicle.**
11. Stow the jack, jack handle and winch handle tools back in the storage compartment.

**WARNING:**

A loose tire or jack thrown forward in a collision or hard stop could endanger the occupants of the vehicle. Always stow the jack parts and the spare tire in the places provided. Have the deflated (flat) tire repaired or replaced immediately.

12. Check the spare tire pressure as soon as possible. Correct the tire pressure, as required.

**For vehicles with aluminum wheels:**

The center cap must be pushed out from the rear to install the retainer and stow the tire.

## Jack And Tools Location

Depending on vehicle trim level, the jack and tools are stored under the front passenger seat in a box, or strapped behind the driver seat in a tool bag. Tools may vary.

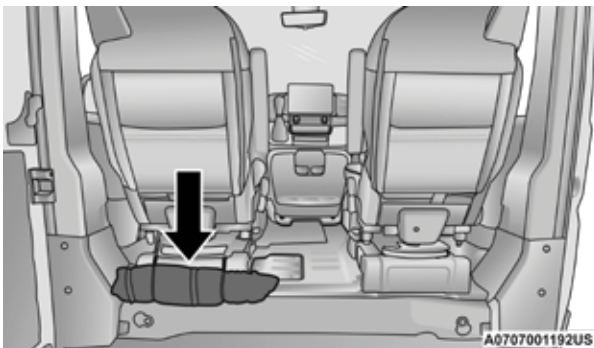

Jack Tool Bag Location — If Equipped



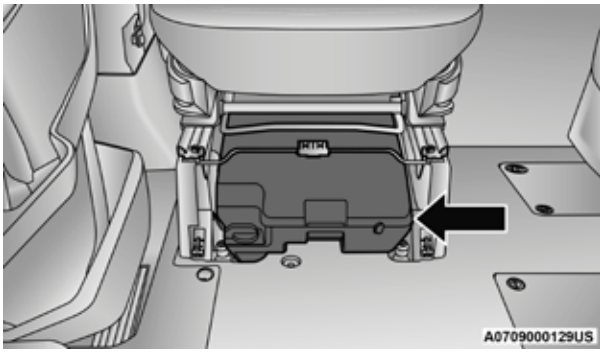

Jack Kit Location — If Equipped

To release the jack kit from its storage location, turn the lock knob a quarter turn counterclockwise to the unlock position.

**CAUTION:**

**Do not force lock knob over limit. Damage to lock knob may occur.**

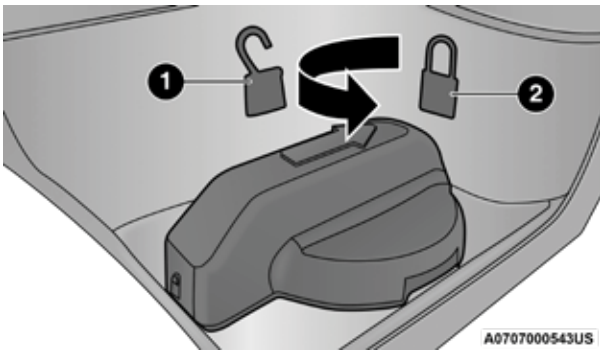

- |                     |
|---------------------|
| 1 — Unlock Position |
| 2 — Lock Position   |

Lock Knob

To open the jack kit container, you must push the container's release to separate the top and bottom.

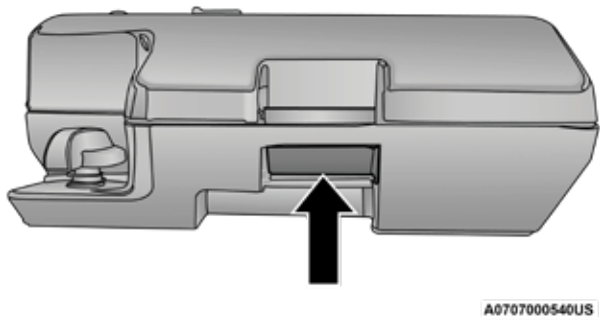

Container Release

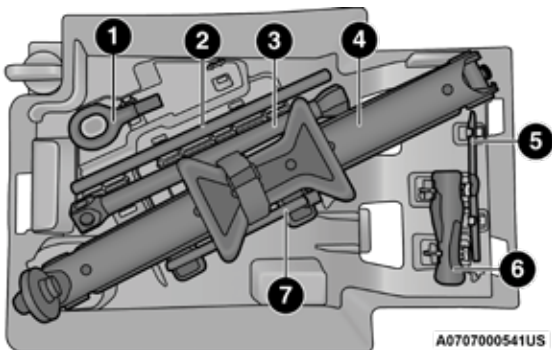

- |                                   |
|-----------------------------------|
| 1 — Tow Eye — If Equipped         |
| 2 — Wrench Handle                 |
| 3 — Lug Bolt Adapter              |
| 4 — Jack                          |
| 5 — Reversible Tool — If Equipped |
| 6 — Tool Handle — If Equipped     |
| 7 — Winch Extension               |

Jacking Tools